

# CBCS SCHEME

USN

--	--	--	--	--	--	--	--	--	--

17ELE15/25

## First/Second Semester B.E. Degree Examination, July/August 2022 Basic Electrical Engineering

Time: 3 hrs.

Max. Marks: 100

Note: Answer any FIVE full questions, choosing ONE full question from each module.

### Module-1

- 1 a. State and explain with neat diagram, Kirchhoff's laws for electric circuits. (06 Marks)
- b. Explain coefficient of magnetic coupling and develop an expression for the same. (07 Marks)
- c. Determine the current in the branches of the network in Fig. Q1 (c).

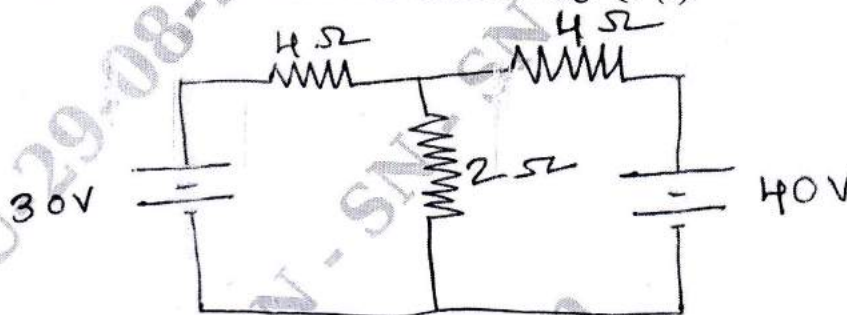

Fig. Q1 (c)

(07 Marks)

OR

- 2 a. State and explain Lenz's law and Fleming's right hand rule. (06 Marks)
- b. In a pair of coupled coils, coil A has 600 turns and carries a current of 2.5 Amps and total flux due to coil is 1.2 mwb and mutual flux 0.8 mwb. If coil 'B' has 2000 turns determine  $L_1$ ,  $L_2$ ,  $m$  and  $K$ . (07 Marks)
- c. Determine the power dissipated in each resistance of the circuit shown in Fig. Q2 (c) and voltage drop across 5 Ω resistor.

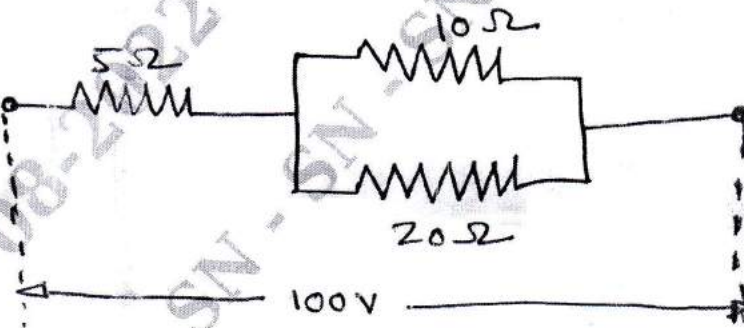

Fig. Q2 (c)

(07 Marks)

### Module-2

- 3 a. With neat sketch, describe the construction of a Dynamo meter type wattmeter. (08 Marks)
- b. Derive an expression for torque developed by a dc motor. (06 Marks)
- c. An 8-pole lap connected armature has 960 conductors, a flux of 40 mwb per pole and a speed of 400 rpm. Determine the EMF generated. If the armature were wave connected at what speed it must be driven to generate 400 volts. (06 Marks)

Important Note : 1. On completing your answers, compulsorily draw diagonal cross lines on the remaining blank pages.  
2. Any revealing of identification, appeal to evaluator and /or equations written eg, 42+8 = 50, will be treated as malpractice.

OR

- 4 a. Draw the curved of armature Current Vs Speed and Armature current Vs Torque of d.c. series and shunt motors. (06 Marks)
- b. With neat sketch, explain principle operation of induction type energy meter. (07 Marks)
- c. The armature of a 4-pole shunt motor has a lap winding accommodated in 60 slots, each containing 20 conductors. If the useful flux per pole is 23 mwb, calculate the total torque developed when the armature current is 50 A. Also calculate back E.m.f when speed of the motor is 1400 rpm. (07 Marks)

Module-3

- 5 a. Define average value, root mean square value, form factor and peak factor of sinusoidally varying quantities. (08 Marks)
- b. Explain with neat sketch plate earthing. (06 Marks)
- c. The resistance of a coil is  $140 \Omega$  and its inductance  $0.85 \text{ H}$ . Determine the current, p.f. and circuit impedance when coil is connected to  $120 \text{ V}$ ,  $60 \text{ Hz}$  supply. (06 Marks)

OR

- 6 a. Explain three way control of lamps with truth table and connection diagram. (06 Marks)
- b. A  $230 \text{ V}$ ,  $50 \text{ Hz}$  as supply is applied to coil of  $0.06 \text{ H}$  inductance and  $2.5 \Omega$  resistance connected in series with a  $6.8 \mu\text{F}$  capacitor. Calculate impedance, current, phase angle between current and voltage, power factor and power consumed. (08 Marks)
- c. Determine the total impedance and current drawn by supply of the circuit shown in Fig. Q6 (c). (06 Marks)

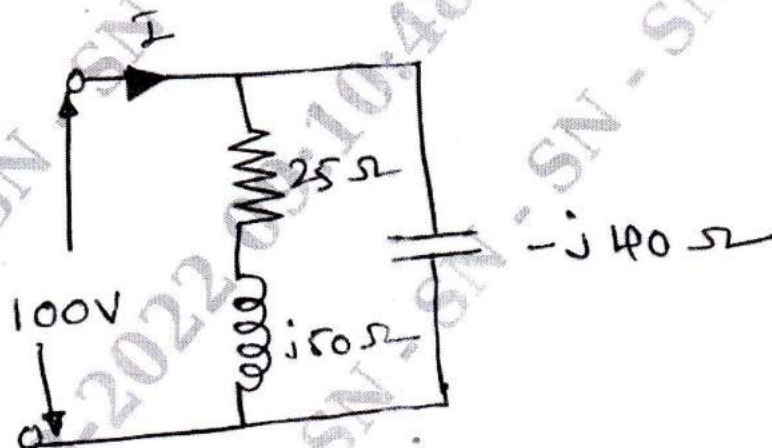

Fig. Q6 (c)

Module-4

- 7 a. Mention advantages of three phase system. (05 Marks)
- b. A balanced 3 phase star connected load is fed from 208 volt, 3-phase supply. Each leg of load has a impedance of  $(15 + j20)\Omega$ . Determine, power factor, active power, reactive power, the phase current and line current of the system. (08 Marks)
- c. A  $50 \text{ Hz}$ , 6-pole synchronous generator has 36 slots and 20 conductors per slot. The flux per pole is  $0.016 \text{ wb}$ . Determine phase and line induced emf when generator is connected in star. If  $K_C = 1$  and  $K_d = 0.966$ . (07 Marks)

**OR**

- 8 a. In a three phase star connection, find the relation, find the relation between line and phase values of current and voltages. Also derive the equation for three phase power. (07 Marks)
- b. Three identical coils, each having a resistance of  $10 \Omega$  and a reactance (inductive) of  $10 \Omega$  are connected in delta. Find the line current and readings on each of the wattmeters to measure the power. Supply voltage is 400 V, 3-phase. (07 Marks)
- c. Derive the emf equation of the synchronous generator. (06 Marks)

**Module-5**

- 9 a. Explain construction and working of single phase transformer. (08 Marks)
- b. A 4-pole, 50 Hz, 3-phase induction motor running with 1440 rpm on full load. Calculate slip of the machine and rotor frequency. (05 Marks)
- c. A single phase transformer is rated 600/200 V, 25 KVA, 50 Hz. Calculate :
- (i) The magnitude of primary and secondary current.
- (ii) What would be the value of maximum core flux when the transformer is excited, given  $N_1 = 60$  turns. (07 Marks)

**OR**

- 10 a. Define slip. Derive an expression for frequency of rotor current. (06 Marks)
- b. Explain the concept of rotating magnetic fields in three phase induction motor. (07 Marks)
- The efficiency of a 400 KVA, 1-phase transformer is 98.77% when delivering full load at 0.8 pf and 99.13% at half full load and unity p.f. Calculate Iron loss and full load Copper loss. (07 Marks)

\*\*\*\*\*